



*Where Quality & Power Meet*

**10 Quart Backpack Vacuum**

**OWNER'S MANUAL**

---

# IMPORTANT SAFETY INSTRUCTIONS

When using an electrical appliance, basic precautions should always be followed, including the following:

**READ ALL INSTRUCTIONS BEFORE USING.**

 **WARNING** - to reduce the risk of fire, electric shock, or injury:

1. Do not leave the appliance unattended when plugged in. Unplug from outlet when not in use and before servicing.
2. Do not use outdoors or on wet surfaces.
3. Do not try to vacuum liquid with this vacuum. This vacuum is for DRY USE only.
4. Do not allow to be used as a toy. Close attention is necessary when used by or near children.
5. Use only as described in this manual. Use only manufacturer's recommended attachments.
6. Do not use with if the cord or plug is damaged. If the appliance is not working properly, has been dropped, damaged, left outdoors, or has been dropped into water, return it to a service center.
7. Do not pull or carry by the cord, use the cord as a handle, close a door on the cord, or pull the cord around sharp edges or corners. Do not run appliance over the cord. Keep the cord away from heated surfaces. Connect to a properly grounded outlet only. See grounding instructions.
8. Do not unplug by pulling on the cord. To unplug, grasp the plug, not the cord.
9. Do not handle the plug or appliance with wet hands.
10. Do not put any object into openings. Do not use with any opening blocked. Keep free of dust, lint, hair, or anything that may reduce air flow.
11. Keep hair, loose clothing, fingers, and all body parts away from openings and moving parts.
12. Turn off before unplugging.
13. Use extra care when cleaning on stairs.
14. Do not use to pick up flammable or combustible liquids, such as gasoline, or use in areas where they may be present.
15. Do not pick up any objects that are burning or smoking, such as cigarettes, matches, or hot ashes.
16. Do not use without a dust bag and /or filters in place.

**SAVE THESE INSTRUCTIONS**

# PROLUX 10 Quart Vacuum Diagram

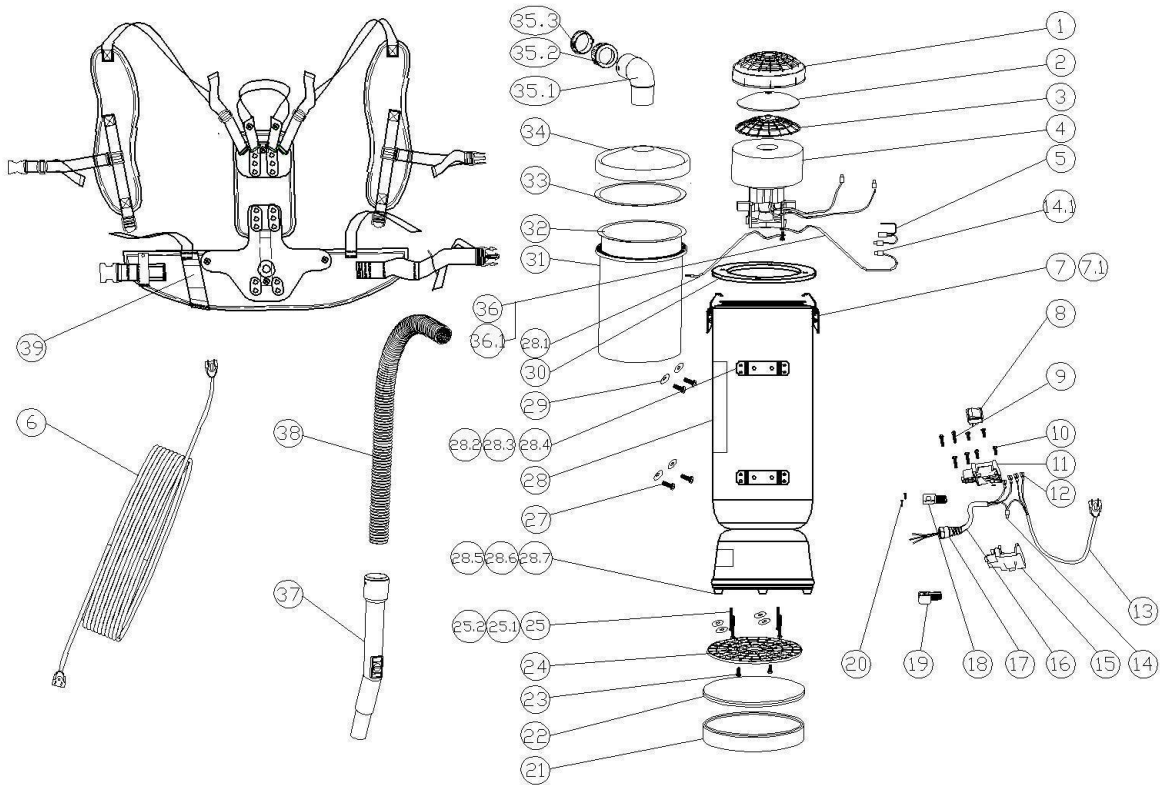

1. Filter guard A 2. HEPA Filter 3. Filter guard B 4. Motor 5. Thermo-protector 6. Extension Cord (not provided) 7. Cover latch A 7a. Screws 8. Switch 9. Screws(M3\*25) 10. Screws(M3\*15) 11. Upper part of switch box 12. Connector terminal and insulator 13. Power supply cords and cord sets 14. Wire connector soldering log 14.1. Wire connector soldering log 15. Lower part of switch box 16. Connection cable 17. Connection cable fixer nut 18. Connection cable fixer part 1 19. Connection cable fixer part 2 20. Screws(M3\*12) 21. Round rubber support 22. Sound muffler (Foam filter) 23 Screws(M5\*10) 24. Plastic air diffuser 25. Screw(M5\*15) and washer 27. Screws (5/16\*15) 28. 10Q Canister 28.1. Grounding wire 28.2. Harness hanger 1 28.3. Aluminum rivet 4.2\*12 28.4. washer 28.5. Φ20 foot gasket 28.6. Screw (M5\*10) 28.7. Fastening Nut M5 29. Big Washer 30. Motor depression ring 31. 10Q inner dust bag 32. 10Q outer dust bag 33. Cover seal ring 34. Cover 35.1. Bent connector tube 35.2. Screw for hose 35.3. Screw cuff 36. Grounding wire 2 36.1. 5 wire connector 37. Handle 38. Hose 39. Harness 40. Rating label 41. Warning Label

---

# INSTALLATION AND OPERATING INSTRUCTION

## INSPECTION

Carefully unpack and inspect your new vacuum for shipping damage. Each unit is tested and thoroughly inspected before shipping.

## WARNING

- DO NOT vacuum with a frayed, worn, or damaged cord.
- DO NOT vacuum liquids or expose the backpack vacuum to rain or water.
- DO NOT vacuum hazardous or toxic materials.
- DO NOT use to pick up flammable or hazardous material

## GROUNDING INSTRUCTIONS

This appliance must be grounded. If it were to malfunction, grounding reduces the risk of electric shock. This appliance is equipped with a cord having an equipment-grounding conductor and grounding plug. The plug must be inserted into an appropriate outlet that is properly installed and grounded in accordance with all local codes and ordinances.

## WARNING

Improper connection of the equipment-grounding conductor can result in a risk of electric shock. Check with a qualified electrician or service technician if you are in doubt as to whether the outlet is properly grounded. Do not modify the plug provided with the appliance. If it will not fit the outlet, have a proper outlet installed by a qualified electrician.

This appliance is for use on a nominal 120-volt circuit and has a grounding attachment plug that looks like the plug illustrated in sketch A. Make sure that the appliance is connected to an outlet having the same configuration as the plug. No adaptor should be used with this appliance.

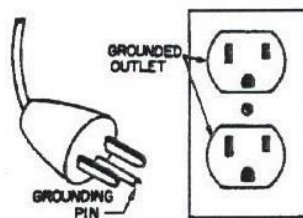

(A)

---

## MOTOR

The Prolux 10-quart back pack vacuum uses the industry's best motor, the Amtek motor. Amtek 119534-00 vacuum motors must never be used in an application in which wet or moist conditions are involved, where dry chemicals or other volatile materials are present, or where airflow may be restricted or blocked. Such motors are designed to permit the vacuumed air to pass over the electrical wiring to cool it. Therefore, any liquid, dry chemical, or other foreign substance which could come in contact with electrical conductors could cause combustion (depending on volatility) or electrical shock. Failure to observe these precautions could result in property damage and severe personal injury, including death in extreme cases.

## THERMO-PROTECTOR INSTRUCTIONS

This appliance is equipped with a thermo-protector, which will cut off the circuit automatically to prevent the motor from overheating. Sufficiently plugging the airway for an extended period will result in the vacuum shutting off. If this occurs, press the switch to turn the vacuum to its "OFF" position and wait about 5 minutes for the motor to cool to a safe operating temperature. Be sure to determine the cause of overheating and rectify the problem before using the vacuum cleaner again, or it will continue to overheat and shut off. In some instances the circuit is cut off because of high motor temperature caused by dust bag clog or airway block. Please unplug the vacuum and check the inner paper dust bag and airway. If the dust bag is too dirty and clogged, replace with a new one. If the airway is blocked, please get rid of the blockage before use. The motor can be restarted when it is cool.

## ELECTRICAL

The vacuum motor operates on a standard 120 volt, 60Hz, AC circuit. Severe changes in voltage, high or low, can cause damage to the motor and cause premature motor failure.

## EXTENSION CORD

To prevent electrical damage, use a 25 ft /16-gauge extension cord (not provided). If you need to use a 100-foot cord, it must be 14-gauge or larger. You may use extension cords up to, but no longer than, 100 feet.

---

## PREPARATION FOR OPERATION

1. Remove the cover (No. 34) and cover seal ring (No. 33) and pull out the cloth dust bag (No. 31). Check to see that the filter guards and filter (No. 1, No. 2 and No.3) have not shifted during shipping. (Figure A)
2. Install an inner paper dust bag (No. 32) inside of the outer cloth dust bag (No. 31). At the beginning of each shift, the bags should be checked. Empty or replace as necessary. The unit comes with 5 extra bags and additional bags are readily available for purchase.

NOTE: Never use a paper dust bag without the cloth dust bag.

3. Place the cover seal ring (No. 33) on the dust bag's opening (No. 32). (Figure B)
4. Replace the cover (No. 34) and clip the sunken edge of the cover tight by pushing downward on the cover clip (No.7).
5. Push the bent connector tube (No. 35) into the cover (No.34), make sure that it inserts into the cover (No. 34) completely and tightly (Figure C).



Figure C



Figure D

6. Check the hose ends to make sure that they fit tightly. In the event a hose end comes apart from the hose, the hose can simply be rethreaded into the hose end.
7. Check the wear on the cord by the vacuum body and at the plug. Pass the power supply cord (No.13) through the strip outside the left side of the waist belt (Figure E).

- 
8. Fix the switch box (No.11 and No.15) under the sewn strap and knot the other strap around the switch box. (Figure F & Figure G).
  9. Loosen the waist belt latch and chest belt latch. In an open area, lift the vacuum by one shoulder strap and slide your free arm into the other strap. (Figure D)
  10. Adjust the shoulder straps to allow the waist belt to be buckled around your waist.
  11. Fasten the waist belt and chest belt snugly and make sure the weight is resting comfortably on your hips.  
NOTE: The back-plate can be adjusted up or down by removing the four screws (No.27) that attach to the vacuum's body. (Figure H)
  12. Attach tools to the handle and make sure the two ends are tightly connected. (Figure I)

## PROPER VACUUMING MOTION FOR LARGE AREA WITH DIRECT SUCTION TOOLS

1. Begin with the wand parallel to your body.
2. Draw the top of the wand in towards your waist and twist at the waist walking back and forward (a side-to-side motion).
3. The motion is similar to mopping and keeps the upper body and arms from tiring.

## MAINTENANCE INSTRUCTION

 **WARNING:** The following information is for use by qualified service personnel only and is to provide guidance for troubleshooting and maintenance.

- ◆ UNPLUG the vacuum when working on the motor or any electrical part.
- ◆ CHECK the condition of all electrical cords before each use.
- ◆ DO NOT lubricate the motor; it is equipped with sealed bearings.
- ◆ The appliance has NO user serviceable parts.

## PROPER STORAGE

When the vacuum is not in use, it should be stored in a dry place

## ELECTRICAL CORD CARE

NEVER stretch the cord tightly between the vacuum and the outlet. A cord that is stretched or pulled will not function properly and creates a hazard.

After vacuuming, unplug the cord and wind it up loosely. DO NOT wind the cord up by wrapping it around your

---

hand and elbow.

## CARING FOR YOUR VACUUM

1. Every time you finish vacuuming, shake out the cloth and paper dust bags (No.31 and No.32).
2. Each week, rinse, dry and return the foam (NO.21) at the bottom of the appliance below the motor.
3. After each shift, wipe the inside and outside of the vacuum with a household cleaning agent.

## FILTER MAINTENANCE

1. Check the paper dust bag (No.32) each time you start and finish vacuuming. A clogged and dirty dust bag restricts airflow and results in reduced suction and overheating.
2. While vacuuming throughout a building, stop every two hours or as needed to shake out the paper dust bag (No.32). Replace the paper dust bag when necessary. (Figure J)  
**NOTE:** Lift both the paper dust bag and cloth bag out at the same time to avoid ripping the paper dust bag, especially if it is full.
3. Once a month (or as needed) hand or machine wash the cloth dust bag (No.31) and let it LINE DRY. (Do not put it in the dryer).
4. Once a month (or as needed) clean the HEPA filter (No.2) between the motor guards, located inside the vacuum under the paper and cloth dust bag. (Figure K)
  - a. Pull the top piece of the motor guard (No.1) off and remove the HEPA filter (No. 2). Shake it out, rinse it and let it air dry thoroughly. Gently using compressed air can be used for a dry clean.
  - b. Before the next use, return the HEPA filter (No.2) to its place. Replace with new foam media if necessary.
  - c. Firmly snap the top piece of the motor guard (No.1) into place.
5. As needed rinse, air dry, and return the foam filter (No.22) at the bottom of the appliance below the motor
  - a. Pull out the round rubber support (No.21) and take foam filter (No.22) out, rinse it and let it air dry thoroughly.
  - b. Before the next use, return the foam filter (No.22) to its place.
  - c. Put the round rubber support (No.22) into the canister to support the foam filter from falling down.



---

## Warranty Information

Your Prolux 10 Quart Back Pack Vacuum is protected by the **3-year Residential Manufacturer motor warranty (1 Year Commercial Manufacturer motor warranty) and a 1-year bumper to bumper warranty**. Warranty does not cover filters which will need to be replaced from time to time depending on use. Should your unit need service or warranty work please contact the authorized dealer that you purchased the unit from for warranty instructions. Prolux only accepts warranty claims from authorized Prolux dealers. These dealers are authorized to do warranty work and stock a wide variety of parts. Prolux and its authorized service centers are responsible for all parts and labor costs associated with any warranty work and the customer is responsible for any shipping costs.

### FOR YOUR RECORDS

Please record the model and serial number below, for easy reference, in case of loss or theft. These numbers are located on the model tag on the unit.

Model number \_\_\_\_\_

Serial Number \_\_\_\_\_

Date of Purchase \_\_\_\_\_

Purchased From \_\_\_\_\_